

EE-SPZ301/401

Photomicrosensor with Built-in Amplifier, Used with Omron E32-Series Standard Optical Fiber Cables

- Light modulation effectively reduces influence of external light interference
- Visible indicator ensures easy optical axis adjustment and monitoring
- Wide operating voltage range: 5 to 24 VDC
- Amplifier output can be directly connected to a programmable logic controller (PLC)
- Easy-to-wire connector type
- Convert to PNP output with EE-2001 conversion connector

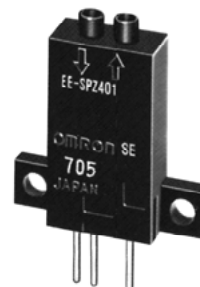

Ordering Information

■ PHOTOMICROSENSORS

Appearance	Type	Output configuration	Part number
	Fiber-connecting	Dark-ON	EE-SPZ301
		Light-ON	EE-SPZ401

■ FIBER UNITS AND ATTACHMENTS

Fiber unit	Attachment	Sensing distance (See note 1.)	Sensing object	Directional angle	Part number
E32-TC200 (transmissive) 2 m cable (See note 2.)	—	20 mm	Opaque, 1-mm dia.	5° to 40°	EE-SPZ301
	E39-F1 Lens	150 mm	Opaque, 4-mm dia. min.		EE-SPZ401 (fiber-connecting)
	E39-F2 Side view lens	10 mm	Opaque, 3-mm dia. min.	20° to 60°	
E32-DC200 (reflective) 2 m cable (See note 2.)	—	1 to 6 mm	15 x 15 mm (white paper)	—	

- Note: 1. The above sensing distances can be achieved when the fiber length is 60 mm (refer to Engineering Data for the relationship between the sensing distance and fiber length).
2. Ambient temperature ranges: -40° to 70°C (-40° to 158°C)(fiber), -40° to 200°C (-40° to 392°C)(attachments); ambient humidity: 35% to 85%

■ ACCESSORIES (order separately)

Name	Part number
Lens unit	E39-F1
Side view lens unit	E39-F2
Fiber cutter	E39-F4
Connector (solder terminals)	EE-1002
Connector with 1 m wire	EE-1003

Specifications

■ RATINGS

Model	EE-SPZ301	EE-SPZ401
Supply voltage	5 to 24 VDC \pm 10%, ripple (p-p): 5% max.	
Current consumption	Average: 15 mA max.; Peak: 50 mA max.	
Operating modes	Dark-ON	Light-ON
Response frequency	100 Hz	
Control output	At 5 to 24 VDC: 80 mA load current (I_C) with a residual voltage of 1 V max. When driving TTL: 10 mA load current (I_C) with a residual voltage of 0.4 V max.	
Light source	GaAs infrared LED (pulse-modulated) with a wavelength of 940 nm	
Receiver	Si photo-diode with a sensing wavelength of 850 nm max.	
Operation indicator	GaP red LED with a wavelength of 700 nm	
Permissible bending radius of fiber	25 mm	

■ CHARACTERISTICS

Ambient illumination	Sensing face: 3,000 lx max. (incandescent light, fluorescent light, and sunlight)	
Enclosure ratings	IP50 (except terminals)	
Ambient temperature	Operating	-10°C to 55°C (14°F to 131°F)
	Storage	-25°C to 65°C (-13°F to 149°F)
Ambient humidity	Operating	35% to 85%
	Storage	35% to 95%
Vibration resistance	Destruction: 10 to 55 Hz, 1.5-mm double amplitude for 2 hrs each in X, Y, and Z directions	
Shock resistance	Destruction: 500 m/s ² (approx. 50G's) for 3 times each in X, Y, and Z directions	
Cable length	5 m max. (AWG24 min.)	

Engineering Data

RECEIVER OUTPUT VS. SENSING DISTANCE (TYPICAL)

EE-SPZ301/SPZ401 with E32-TC200

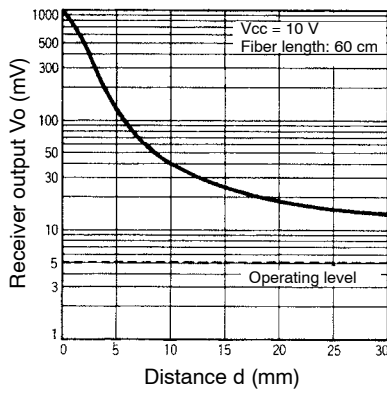

EE-SPZ301/SPZ401 with E32-TC200 and E39-F1

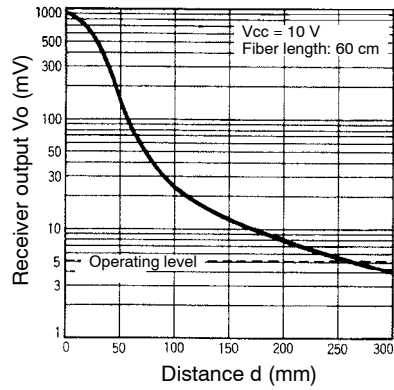

EE-SPZ301/SPZ401 with E32-TC200 and E39-F2

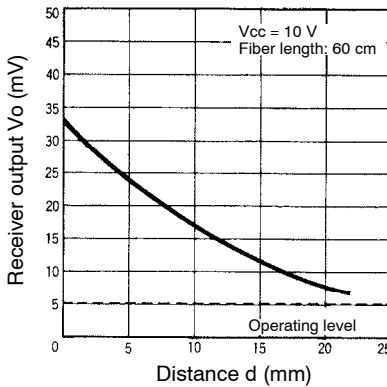

EE-SPZ301/SPZ401 with E32-DC200

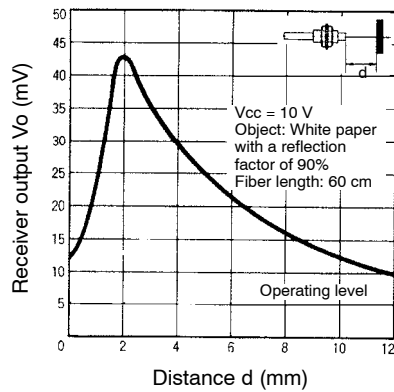

SENSING ANGLE CHARACTERISTICS (TYPICAL)

EE-SPZ301/SPZ401 with E32-DC200

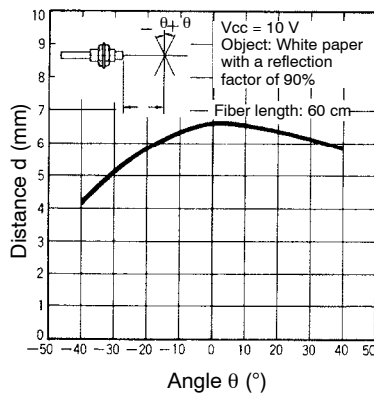

RECEIVER OUTPUT VS. BENDING RADIUS OF FIBER (TYPICAL)

EE-SPZ301Y-01/SPZ401Y-01

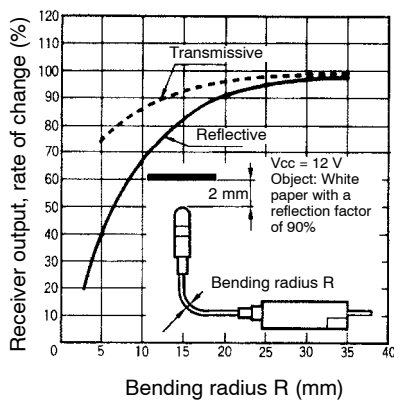

■ SENSING POSITION CHARACTERISTICS (TYPICAL)

EE-SPZ301/SPZ401 with E32-TC200

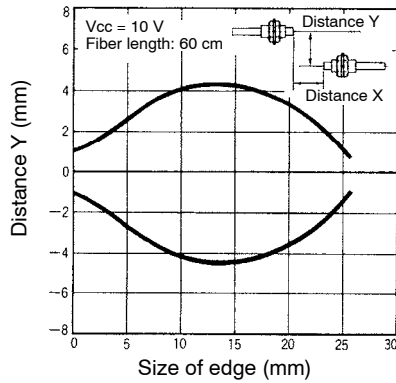

EE-SPZ301/SPZ401 with E32-TC200 and E39-F1

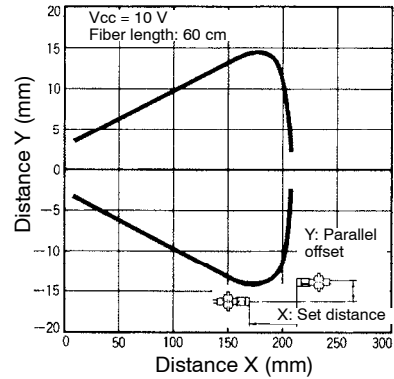

EE-SPZ301/SPZ401 with E32-TC200 and E39-F2

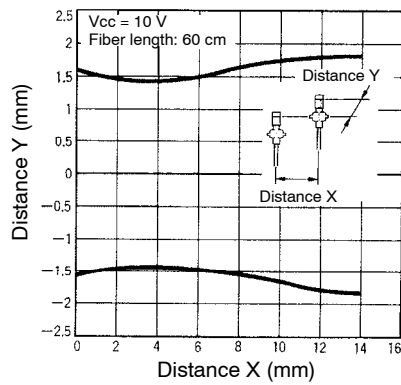

EE-SPZ301/SPZ401 with E32-TC200 and E39-F1

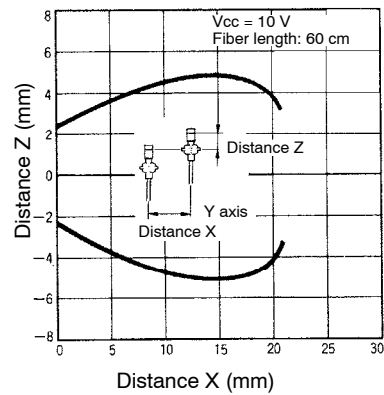

EE-SPZ301/SPZ401 with E32-DC200

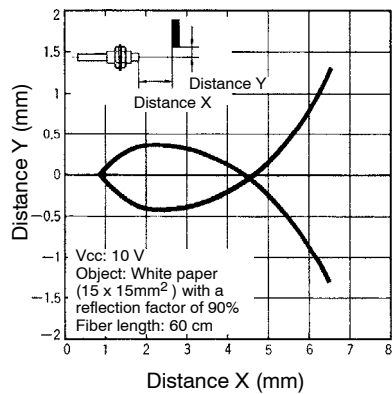

FIBER LENGTH VS. RELATIVE SENSING DISTANCE (TYPICAL)

EE-SPZ301/SPZ401 with E32-TC200

EE-SPZ301/SPZ401 with E32-DC200

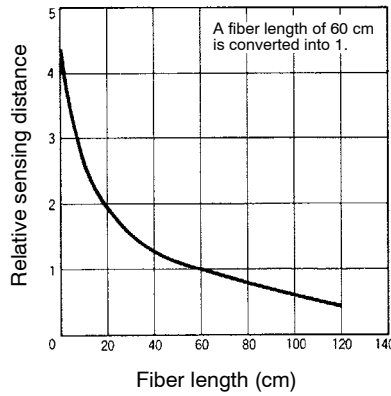
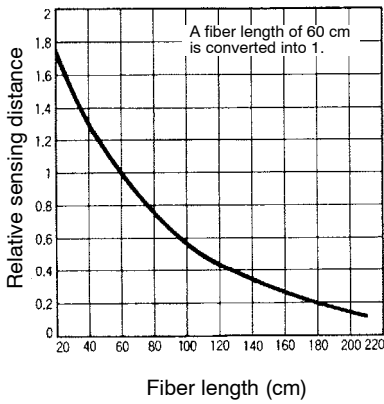

Operation

INTERNAL/EXTERNAL CIRCUIT DIAGRAM

Light-ON/Dark-ON

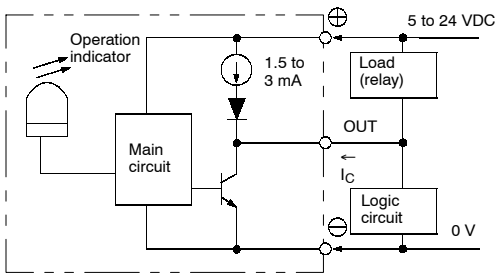

TIMING CHART

Light-ON

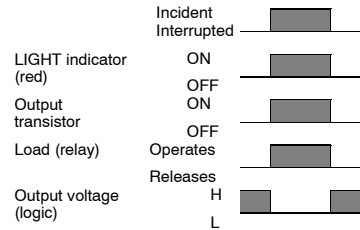

Dark-ON

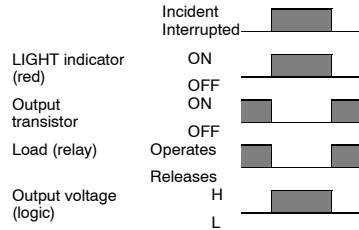

Dimensions

Unit: mm (inch)

EE-SPZ301, EE-SPZ401

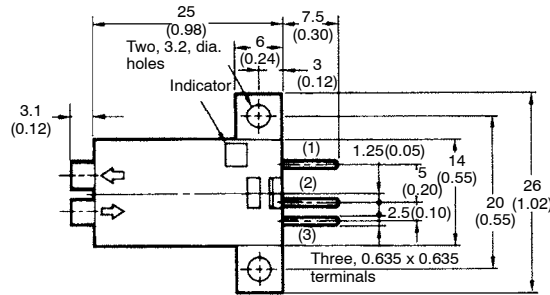
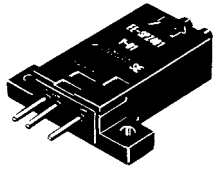

Terminal Arrangement

(1)	⊕	V _{CC}
(2)	OUT	OUTPUT
(3)	⊖	GND (0 V)

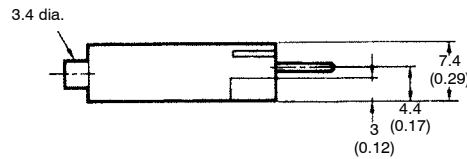

E32-TC200 STANDARD FIBER (SLOT)

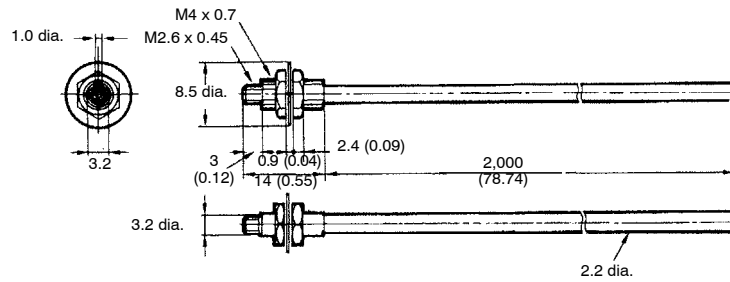
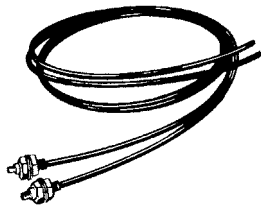

E32-DC200 STANDARD FIBER (DIFFUSE)

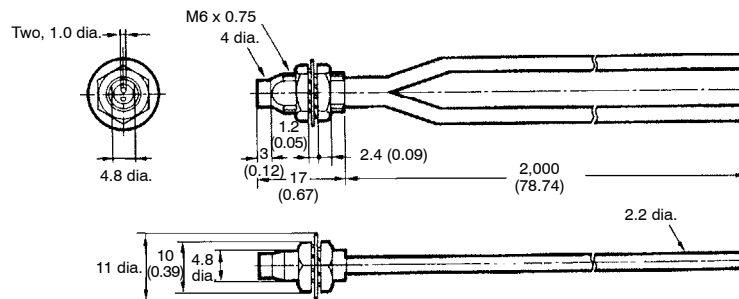
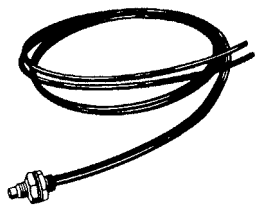

■ EE-1002 SOLDER CONNECTOR

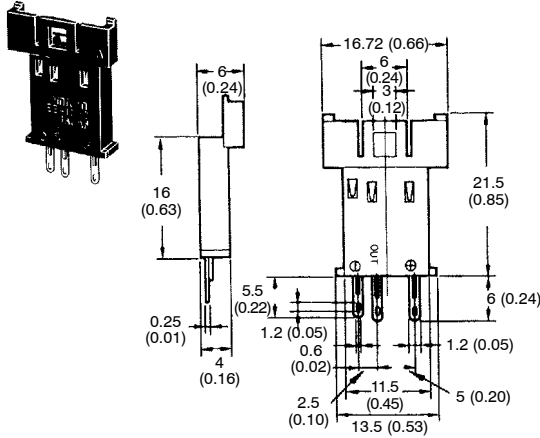

■ EE-1003 CONNECTOR WITH CABLE

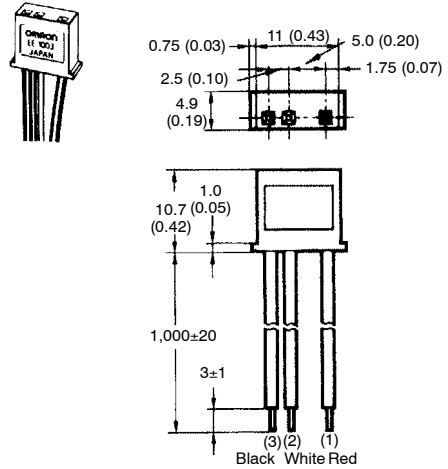

■ EE-SPZ + EE-1003

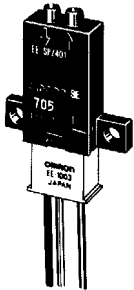

Terminal Arrangement

(1)	Brown (Red)	⊕	V _{CC}
(2)	Black (White)	OUT	OUTPUT
(3)	Blue (Black)	⊖	GND (0 V)

Note: Older standard colors are shown in parentheses. The connector comes with a 1-m attached cable.

■ EE-1003A CONNECTOR HOLDER

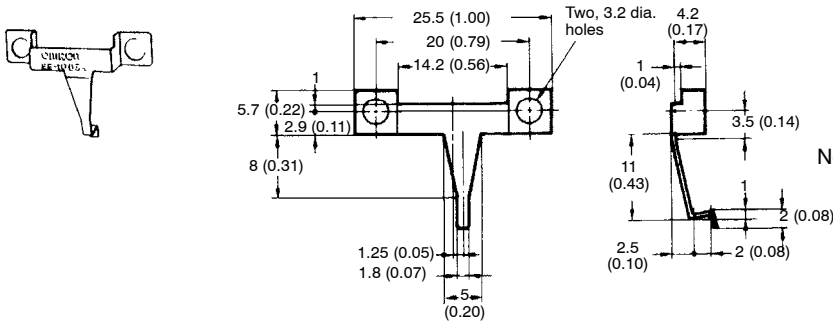

Note: Use the EE1003A Connector Holder to prevent accidental disconnection of the EE-1003 Connector from the EE-SPZ301/401 Photomicrosensor.

■ ATTACHMENTS

E39-F1 Lens Unit

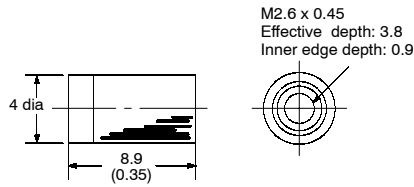

Note: Sold in pairs.

E39-F2 Side View Lens Unit

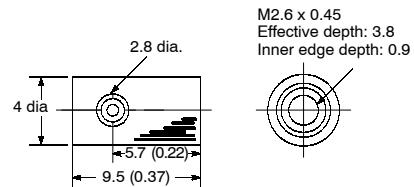

Note: Sold in pairs.

E39-F4 Cutter

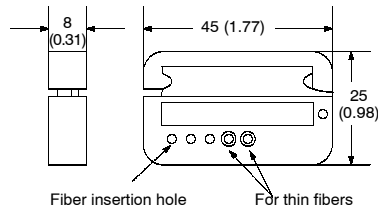

Note: Sold with OMRON's Fiber Units that can be cut to length.

Precautions

Refer to the Technical Information Section for general precautions.

■ WIRING

A fiber that has been once connected cannot be disconnected for reuse.

A cable with a thickness of AWG24 min. and a length of 5 m max. should be connected to the output terminals.

To use a cable longer than 5 m, attach a capacitor with a capacitance of approximately 10 μF to the wires, as shown below. The distance between the terminal and the capacitor must be within 5 m:

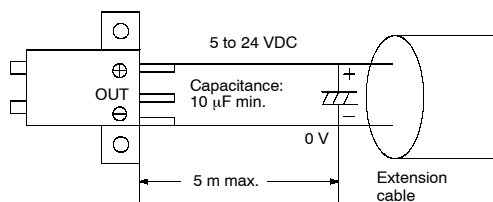

The sensing distance of the EE-SPZ301/401 with the E32-DC200 in this data sheet was achieved using white paper with a reflection factor of 90%.

The background object should not be excessively glossy when using the EE-SPZ301/401 with the E32-DC200.

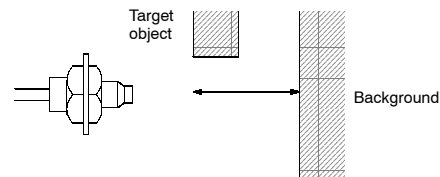

Keep an appropriate distance between the sensor and the background object. The background surface should be covered with a material that has a small reflection factor, such as a black sponge sheet.

Do not solder the cable to the connectors. Use the EE-1002 Connector or EE-1003 Connector (with a 1-m cable attached) to connect the cable to the output terminals.

Use the EE1003A Connector Holder to prevent accidental disconnection of the EE-1003 Connector from the EE-SPZ301/401 Photomicrosensor.

Do not impose excessive force on the terminals (refer to the graphics below). Excess force will damage the terminals.

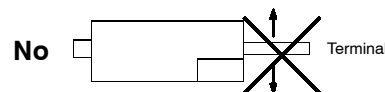

If the metal mounting base is subjected to inductive electrical noise, the photomicrosensor can be activated accidentally. If noise is a problem, take the following precautions:

1. Connect the negative terminal to the mounting base so that there will be no difference in electric potential between the photomicrosensor and mounting base.
2. Connect the negative terminal to the mounting base with a 0.47- μ F capacitor.
3. Insert a plastic insulating plate with a thickness of approximately 10 mm between the photomicrosensor and mounting base.

Wire, as shown by the following illustration, to connect a small inductive load (a relay for example) to the photomicrosensor. A diode must be connected parallel to the relay to absorb the reverse voltage.

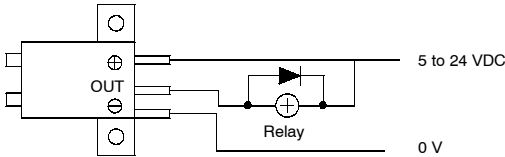

The possible sensing distance differs for each EE-SPZ301/401 model when used with the E32-DC200. The differences are, however, within 6 to 10 mm using white paper with a reflection factor of 90%.

■ TIGHTENING THE FIBER UNIT

Tighten the Fiber Unit at a torque less than 8kg-cm. Use the correct spanner to tighten the Fiber Unit.

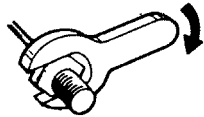

■ INSERTING THE FIBER UNIT

Do not pull or push the Fiber Unit with excessive force. Bend the fiber in as large a radius as possible and 25 mm min. Do not bend the portions between the both ends and 40 mm from the ends of the fiber.

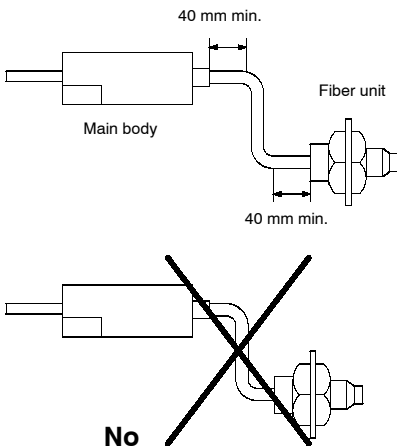

Install the Fiber Unit with nylon cable holders or cable ties as shown below so that no excessive force is directly applied to any section of the cable.

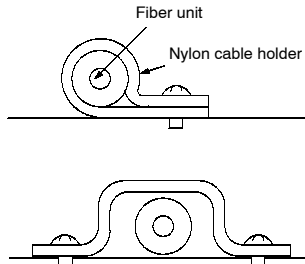

■ INSTALLATION

When installing three or four transmissive-type photomicrosensors in parallel, do not mount all the emitters on one side and the receivers on the other side. Mount each pair of emitter and receiver so that it emits light in the opposite direction from the next pair.

Two reflective photomicrosensors mounted in parallel could malfunction if they are used to sense an object moving at slow speed.

The operating temperature of the amplifier unit must not exceed 55°C.

The connection force between the fiber and the photomicrosensor will decrease when the ambient temperature is high. If high ambient temperature can be expected, install the fiber with a holder or clip, so the fiber will not pull off.

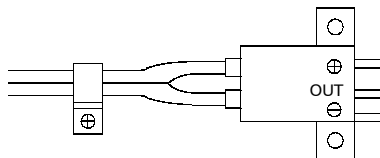

Install the fiber with a holder or clip.

■ POWER SUPPLY

When using a standard switching regulator, ground the FG and G terminal to ensure that the photomicrosensor will be in a stable operating condition.

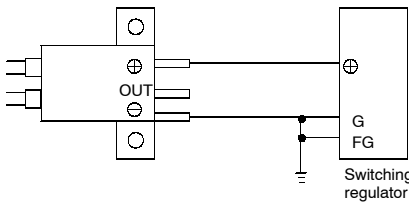

■ CHEMICAL RESISTANCE

Do not use the photomicrosensor in an atmosphere containing organic solvents, such as paint thinner vapor.

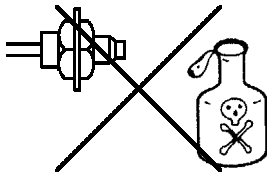

No

■ CASING

The casing material is a polycarbonate resin, which is soluble in alkali, aromatic hydrocarbons, and aliphatic hydrocarbonate chloride solvents.

■ CUTTER

Use the E39-F4 Cutter and cut the fiber carefully to ensure proper optical connection.

1. Insert the fiber, to the desired cutting length, into a previously unused hole in the Cutter.
2. Push down the blade in one strong, smooth motion.

Do not re-use a hole that has been used once to cut a fiber cable. The chances of a cut surface being cut irregularly greatly increase, which would in turn shorten the cable's sensing distance.

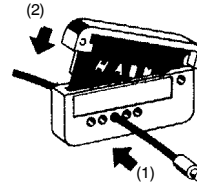

Insert the fiber into the EE-SPZ301/401.

Note: A fiber that has been connected cannot be disconnected for re-use because the locking capacity of the fiber on the EE-SPZ301/401 side will be lost.

NOTE: DIMENSIONS SHOWN ARE IN MILLIMETERS. To convert millimeters to inches divide by 25.4.

OMRON®

OMRON ELECTRONICS LLC

One East Commerce Drive
Schaumburg, IL 60173

1-800-55-OMRON

OMRON ON-LINE

Global - <http://www.omron.com>
USA - <http://www.omron.com/oei>
Canada - <http://www.omron.com/oci>

OMRON CANADA, INC.

885 Milner Avenue
Toronto, Ontario M1B 5V8

416-286-6465